

Description	"Maxi" FRL service units with pressure gauge are of modular design with exchangeable insert kits and have a high flow rate. All "maxi" instruments are easy to take out of fixed piping by simply removing the two fastening bolts on the insert kits.	
Media	compressed air or non-corrosive gases	
Supply pressure	max. 17 bar	by T-handle with locknut at C21
Adjustment	by plastic knob with snap-lock at C20, relieving, optionally non-relieving	Filter element 40 µm, optionally 5 µm, made of polypropylene
Relieving function	G¼ on both sides of the body	Bowl metal version with sight glass
Gauge port	manual drain as standard,	optionally automatic drain or semiautomatic drain for max. 12 bar
Drainage	0 °C to 70 °C / 32 °F to 158 °F	
Temperature range	0 °C to 50 °C / 32 °F to 122 °F for automatic or semiautomatic drain version	
Material	Body: zinc die-cast Knob (C20): glass fibre-reinforced plastic Bowl: zinc die-cast Elastomer: NBR/Buna-N	Spring cage: zinc die-cast T-handle (C21): steel Sight glass: polyurethane Inner valve: brass and plastic

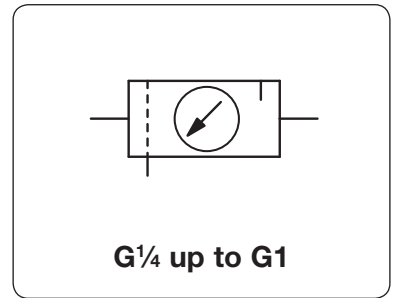

Dimensions			Combination consisting of	Bowl design made of / with	Flow rate		Connection thread G	Order number
A	B	C			m³/h*1	l/min*1		

FRL unit, 2-part			P1: max. 17 bar, P2: 0.3...9 bar, 40 µm, manual drain, relieving, with pressure gauge					C20
178	289	175	B+L20	metal / sight glass	102	1700	G¼	C20-02BL-W
					174	2900	G¾	C20-03BL-W
					276	4600	G½	C20-04BL-W
203	289	175	B+L20	metal / sight glass	390	6500	G¾	C20-06BL-W
					402	6700	G1	C20-08BL-W



FRL unit, 3-part			P1: max. 17 bar, P2: 0.3...9 bar, 40 µm, manual drain, relieving, with pressure gauge					C20
270	226	171	F+R+L20	metal / sight glass	102	1700	G¼	C20-02FRL-W
					174	2900	G¾	C20-03FRL-W
					276	4600	G½	C20-04FRL-W
292	226	171	F+R+L20	metal / sight glass	390	6500	G¾	C20-06FRL-W
					402	6700	G1	C20-08FRL-W



Accessories, add the appropriate letter

T-handle	including locknut	C21-0 . . . -W
5 µm filter element		C20-0 . . . -WG
NPT	connection thread	C20-0 . . . -WN
0.2... 4 bar pressure range		C20-0 . . . -WB
0.5...17 bar pressure range		C20-0 . . . -WD
semiautomatic drain	RK500SY, max. 12 bar	C20-0 . . . -WM
automatic drain	SA605MD, max. 12 bar	C20-0 . . . -WR

Accessories, enclosed

mounting bracket	mounting at the spring cage	BW45-02
mounting nut	made of aluminium	M45x1,5A
mounting bracket set	made of steel, consisting of two mounting brackets	MK20-0100
porting block	tap G¼, for unlubricated compressed air	IK20CP
switch-on valve	lockable 3-port/2-way valve	IK20V

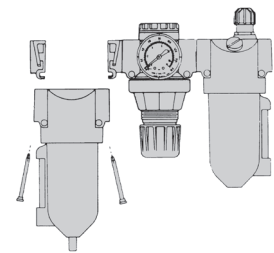
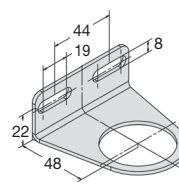
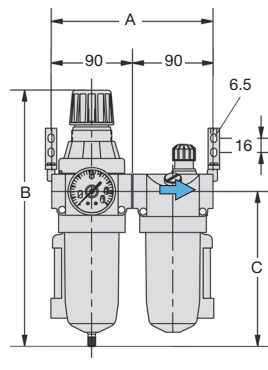
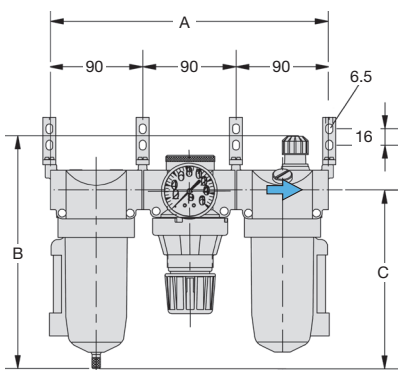
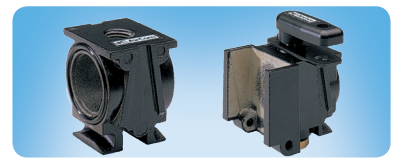

*1 at 8 bar supply pressure, 6 bar outlet pressure and 1 bar pressure drop

Further details: see chapter for single devices
Spare parts: see separate spare parts list

PDF CAD
www.aircom.net

Order example:
C20-02BL-W